

AEONLABS Smart Concrete

Open Hardware for Construction Sites

Rev. 0.1



PRODUCT BRIEF

www.AEONLABS.SCIENCE

1 | Overview

This smart device is able to do active monitoring of fresh concrete at any construction site to determine accurately the concrete strength in pre-determined time intervals. This gives an advantage to a construction site team, to accurately know the exact day the concrete structural element can have formworks removed, **and this saves time and money**. The open hardware electronics available on GitHub have the basic functionalities to function without the need for a cloud server and instead provide the information on local devices of the Engineering Team on site. Commercial versions of the *Smart Concrete* Devices are able to...

- do validation of sensor measurements using AeonLabs Unique Data Fingerprint Identification combined with synchronization of data records to a data repository.
- Wide range of wireless communications: LoRa, 2.4GHz WIFI & Bluetooth, GSM 4G;
- connect up to 5 sensor probes

AeonLabs **Unique Data Fingerprint Identification is an important feature when considering cases of legal dispute of concrete quality**.

This *Smart Concrete* device has built-in extreme low-power management that enables this device to run on battery power for months without the need to charge its batteries.

Beyond its flexible power management, this smart device excels in communications capabilities, with the option of LoRa/LoRaWAN solutions. It boasts integrated functionalities, including 2.4 GHz, 802.11 b/g/n Wi-Fi, and Bluetooth 5 (LE) connectivity, providing a comprehensive suite of communication options with long-range capabilities.

AEONLABS *Smart Concrete* is compatible with ESP-IDF, Arduino, PlatformIO, and MicroPython.

Features

Smart Concrete rev 09-2024

- > Uses ExpressIF ESP32-C3 (32-bit 160MHz) microcontroller
- > Memory Size: 4MB Flash
- > 1x ADC Channel - it can connect to DS18B20 temperature sensors sold on AliExpress
- > Advanced Power Management
 - 2x Connectors for 4.2V Lithium Polymer Batteries
 - 1x 5.0V USB-C connector
 - Power level meter
- > 2.4 GHz Connectivity
 - Ceramic antenna WiFi - IEEE 802.11 b/g/n-compliant
 - Bluetooth LE: Bluetooth 5, Bluetooth mesh
 - Zigbee, Matter, etc
 - Wi-Fi and Bluetooth share the same antenna
- > LoRa WAN Connectivity
 - Frequency bands: 862MHz to 928MHz
 - Signal power: 22dBm
 - Transmission distance: 10km
- > 4G LTE Connectivity
- > Interfaces: USB-C
 - for firmware updates / upgrades
 - installation of a custom firmware possible (tunning)
 - for local troubleshooting or errors on the device
- > Cryptographic hardware acceleration
 - AeonLabs Unique Data Fingerprint Identification for validation of concrete data with increased trustworthiness

Deep Stop Mode (Extreme low power)

An effective alternative to the deep sleep mode of EspressIF's microcontrollers. Deep Stop mode consists of a power latch and RTC combined with a smart power management system that controls the MCU, and all loads connected to the 3V3 path. Controlling the power supply to all connected loads makes it possible to minimize power consumption, thus increasing the life of the battery.

Unique Data Fingerprint Identification

AeonLabs Unique Data Fingerprint Identification is a decentralized approach to validate and maintain a trustworthy database of sensor data measurements in real-time, publicly accessible, through data redundancy, validation, and authentication of datasets across multiple smart concrete devices connected locally or remotely.

Data trustworthiness and sovereignty are ensured with the real-time generation of a Unique Data Fingerprint Identification (UDFID) for a single sensor data record. Additional Smart Concrete Devices can enter a Swarm Network via a blockchain smart contract, regulating access and operational conditions in a fully autonomous way. This allows data acquisition of much larger datasets containing concrete measurements, validated and authenticated publicly, while at the same time made available for analysis from sources outside a specific construction site.

This allows a substantial increase in the trustworthiness of the quality of a concrete element to unknown third-party individuals and auditing enterprises.

2 | Block diagram

AeonLabs Smart Concrete – rev 09-2024

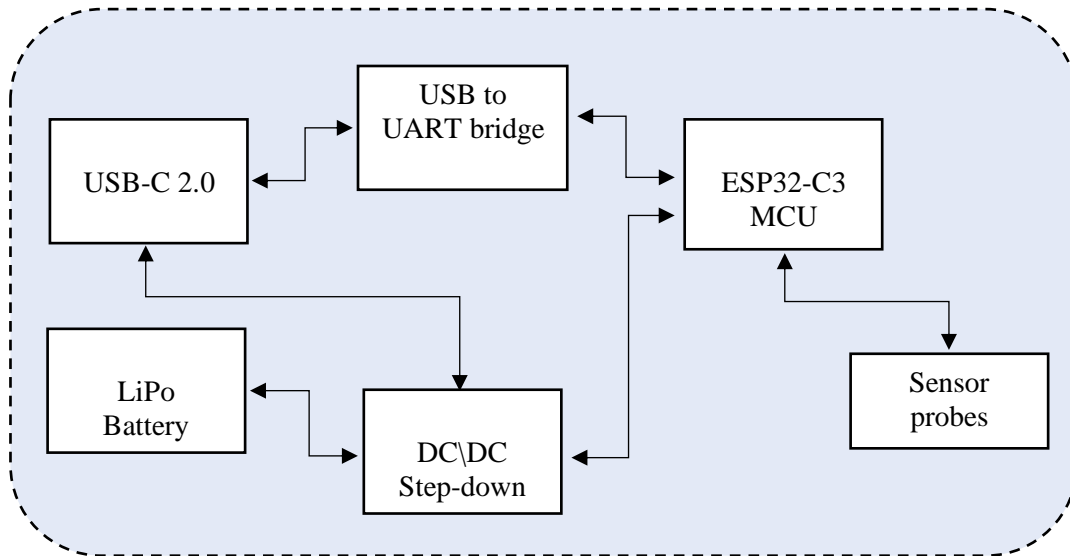

Power switch: Switch to turn DC/DC on/off - remove power from the 5V and 3V3 paths.

USB-C Type 2.0: To power up and program the microcontroller.

USB to UART bridge: IC with an auto-reset circuit, for programming the module via USB-C.

DC step-down: voltage regulator controller (5V to 3.3V, max 1.5A).

ESP32-C3: The core microcontroller of the board

Lithium Polymer Battery connectors: Two JST 2.0mm 2-pin connectors compatible with OEM LiPo Batteries

JST connectors: The board incorporates multiple JST connectors with 2.00mm pitch. These connectors are specifically designed to facilitate interface functionality with various onboard components, including power supplies and sensor probes.

Aeon Labs[®]
where ideas turn to reality for everyday life

Contact AeonLabs today

LinkedIn: www.linkedin.com/company/aeonlabs

Join the Discord Server: <https://discord.gg/hw3j3RwfJf>

Join the Facebook Group: <https://www.facebook.com/groups/1604916820367051>

Full Datasheet not available yet

www.AEONLABS.SCIENCE